

Datasheet

FS9721_LP1

4,000 counts auto range DMM IC

FORTUNE,
Properties
For Reference Only

Fortune Semiconductor Corporation**富晶電子股份有限公司**23F., No.29-5, Sec. 2, Zhongzheng E. Rd.,
Danshui Town, Taipei County 251, Taiwan

Tel. : 886-2-28094742

Fax : 886-2-28094874

www.ic-fortune.com

This manual contains new product information. **Fortune Semiconductor Corporation** reserves the rights to modify the product specification without further notice. No liability is assumed by **Fortune Semiconductor Corporation** as a result of the use of this product. No rights under any patent accompany the sale of the product.

Contents

1. DESCRIPTION	3
2. FEATURES	3
3. MEASURABLE MODES.....	3
4. APPLICATION	4
5. BLOCK DIAGRAM	4
6. PIN DIAGRAM.....	5
7. PIN DESCRIPTION	5
8. DICE PAD LAYOUT & PAD COORDINATE	8
9. TECHNICAL SPECIFICATION (VDD=3V, TA=25°C).....	10
10. MEASUREMENT MODE SELECTION.....	12
11. KEYS DEFINITION	14
12. OTHER FUNCTIONS	14
13. LCD DISPLAY	16
14. APPLICATION DESCRIPTION	17
15. PACKAGE OUTLINE.....	37
16. DEMO BOARD	38
17. ORDERING INFORMATION.....	41
18. REVISION HISTORY	42

1. Description

FS9721_LP1 is a high performance, low power consumption, $3^{3/4}$ digits (4000 Counts) Analog/Digital Converter (ADC+MCU) that is embedded microprocessor. It contains 8 bit microprocessor, low noise and high stability operation amplifier, AC commutation operation amplifier, voltage promotion and voltage regulated power source, high stability bandgap, auto measurement switch and function control circuit, buzzer driver circuit, clock oscillator circuit, Backlight display control circuit, LCD display driver circuit and so on.

Due to FS9721_LP1 is embedded microprocessor so that it can control the logic function during passing I/O. Measurement functions can be combined differently by using MEA1~MEA4 pins and CAP pin code; through the setting to the code can build the fully auto and manual measurement meter. There are Range, Select, Hold, Rel, BLCTR, Hz/Duty and Reset keys so that you can fulfil measurement selection, functions switch, data hold, Backlight display, relative value, frequency and duty cycle measurement, reset and so on functions through these keys. FS9721_LP1 also has auto power-off function. If there is no any action in 15 minutes for the switch or keys of the meter, the system will enter the sleeping mode to save power.

FS9721_LP1 is embedded display driver circuit that is designed for driving LCD. FS9721_LP1 is manufactured by large intergrated circuit technology that has rised hugely the reliability of product and made the design be easy and the volume be small; the system takes 3V power source of low consumption for battery supply that is fit especially to the palm mode meter. FS9721_LP1 is a multi-measurement AC/DC converter that embedded the microprocessor. Only less addition of external components, you can constitute a high accuracy, multi-function and low cost meter.

2. Features

- 2.1 Maximum Display: 4000 ($3^{3/4}$ digits).
- 2.2 Converter Rate: 3 times/sec.
- 2.3 Measurement Mode: Fully Auto/Manual.
- 2.4 The Negative Instruction: Auto.
- 2.5 Power Voltage Range: 2.4V~3.6V.
- 2.6 Chip Power Consumption: $\leq 6\text{mW}$.
- 2.7 Low Battery Warning: About 2.4 V.
- 2.8 Buzzer Driver Circuit (Frequency is about 2.7kHz).
- 2.9 Embedded OPAMP for DC/AC switch.
- 2.10 Function Keys: Range, Hold, Rel, Select, BLCTR, Hz/Duty, Reset.
- 2.11 Unit Symbol and Backlight Display.
- 2.12 Auto Power-off.

3. Measurable Modes

- 3.1 DC Voltage: 400.0mV,4.000V,40.00V,400.0V,1000V.
- 3.2 AC Voltage: 400.0mV,4.000V,40.00V,400.0V,1000V.
- 3.3 DC: 400.0 μA / 4000 μA ,40.00mA / 400.0mA,10.00A.
- 3.4 AC: 400.0 μA / 4000 μA ,40.00mA / 400.0mA,10.00A.
- 3.5 Resistance: 400.0 Ω ,4.000k Ω ,40.00k Ω ,400.0k Ω ,4.000M Ω ,40.00M Ω .
- 3.6 Capacitance: 5.120nF,51.20nF,512.0nF,5.120 μF ,51.20 μF ,200.0 μF (30Sec).
- 3.7 Frequency: 9.999Hz,99.99Hz,999.9Hz,9.999kHz,99.99kHz,999.9kHz,9.999MHz.
- 3.8 Duty Cycle: 0.1%~99.9%.
- 3.9 Diode: 0V~1.5 V.
- 3.10 Short Circuit Testing: Sound when lower than 50 Ω .
- 3.11 Triode hFE: 0~4000.
- 3.12 Temperature Measurement: $^{\circ}\text{C}$.

4. Application

- 4.1 Auto/Manual Measurement Palm Mode Digital Multi-Function Meter.
- 4.2 Auto/Manual Measurement Card Digital Multi-Function Meter.
- 4.3 Auto Measurement Pen Digital Multi-Function Meter.
- 4.4 Auto Measurement Clinch Meter (Hook Meter, Clamp Meter, etc.)
- 4.5 Number Panel Meter.

5. Block Diagram

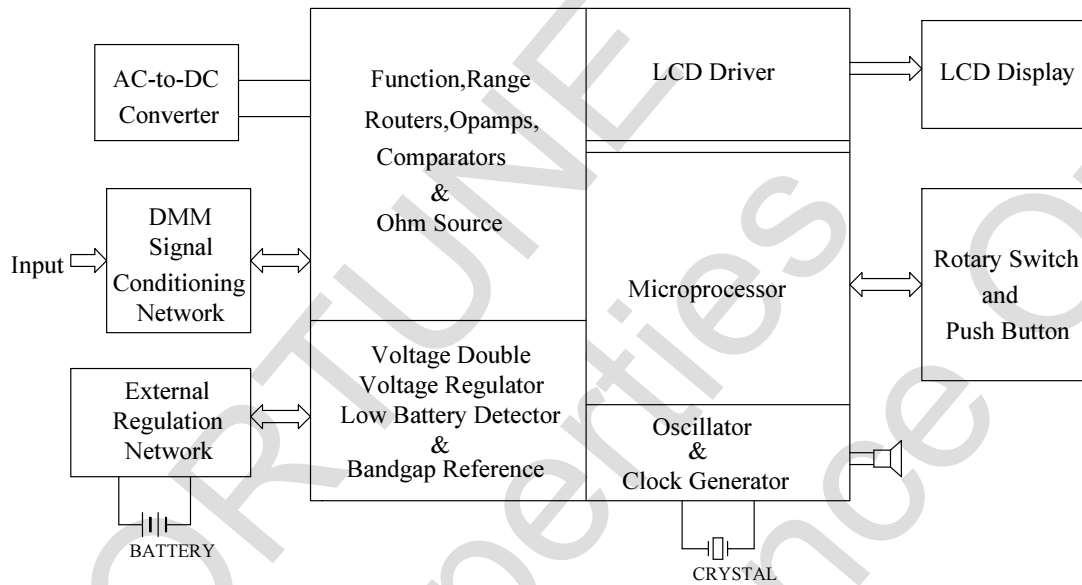

Diagram 1 Block Diagram

6. Pin Diagram

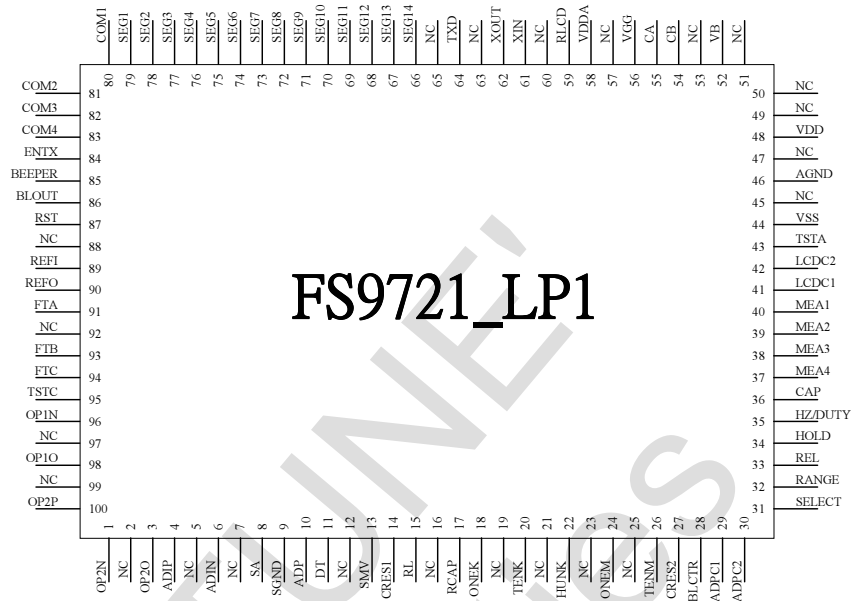

Diagram 2 100 PIN Package

7. Pin Description

Package 100	Pad 78	SYMBOL	I/O	Description
1	1	OP2N	I	Negative Input of DC/AC Converter Operation Amplifier
2		NC		Empty Pin
3	2	OP2O	O	Output of DC/AC Converter Operation Amplifier
4	3	ADIP	I	ADC Positive Input of AC Measurement
5		NC		Empty Pin
6	4	ADIN	I	ADC Negative Input of AC Measurement
7		NC		Empty Pin
8	5	SA	I	ADC Input of Current Measurement
9	6	SGND	I	ADC Negative Input of Analog Ground Connection
10	7	ADP	I	Extra ADC Positive Input
11	8	DT	I/O	Voltage Division Resistance Connect Point of Diode Measurement
12		NC		Empty Pin
13	9	SMV	I	High Resistance Voltage Input/ ADC Positive Input of Resistance Measurement/ Voltage Division Resistance Connect Point of Diode Measurement
14	10	CRES1	I/O	Wave Filter Capacitance Connect Point of Measuring Point of Resistance Measurement
15	11	RL	I	Reference Voltage Negative Input of Resistance Measurement
16		NC		Empty Pin
17	13	RCAP	I/O	Calibrating Resistance Connect Point of Capacitance Measurement
18	14	ONEK	I/O	Resistance 1.001kΩ Connect Point of Voltage and Resistance Measurement
19		NC		Empty Pin
20	15	TENK	I/O	Resistance 10.010kΩ Connect Point of Voltage and Resistance Measurement
21		NC		Empty Pin
22	16	HUNK	I/O	Resistance 101.010kΩ Connect Point of Voltage and Resistance Measurement

23		NC		Empty Pin
24	17	ONEM	I/O	Resistance 1.111MΩ Connect Point of Voltage and Resistance Measurement
25		NC		Empty Pin
26	18	TENM	I/O	Resistance 10.000MΩ Connect Point of Voltage and Resistance Measurement
27	19	CRES2	I/O	Regulating Capacitance Connect Point of Voltage and Resistance Measurement
28	20	BLCTR	I	Backlight Output Control
29	21	ADPC1	I	Current Measurement Mode Select (See 12.4 and 14.13)
30	22	ADPC2	I	Measure Signals DC/AC Select (See 12.4)
31	23	SELECT	I	Measurement Function Selection
32	24	RANGE	I	Auto/Manual Measurement Selection
33	25	REL	I	Relative Value Measurement
34	26	HOLD	I	Display Hold
35	27	HZ/DUTY	I	Frequency/Duty Cycle Measurement Selection
36	28	CAP	I	Fully Manual Measurement Function Selection
37	29	MEA4	I	Measurement Function Selection
38	30	MEA3	I	Measurement Function Selection
39	31	MEA2	I	Measurement Function Selection
40	32	MEA1	I	Measurement Function Selection
41	33	LCDC1	I	Auto Measurement Is Not Used; For Manual Measurement, See Note 3 and 8 in Page 12
42	34	LCDC2	I	Not Used
43	35	TSTA	I	Test Terminal
44	36	VSS	I	Negative Input of Power
45		NC		Empty Pin
46	37	AGND	I	Ground Connect Point of Analog Signal
47		NC		Empty Pin
48	38	VDD	I	Positive Input of Power
49		NC		Empty Pin
50		NC		Empty Pin
51		NC		Empty Pin
52	39	VB	I	Bias Current Input
53		NC		Empty Pin
54	40	CB	I/O	Negative Connect Point of Charge Pump Capacitance
55	41	CA	I/O	Positive Connect Point of Charge Pump Capacitance
56	42	VGG	I/O	Output of Charge Pump Circuit
57		NC		Empty Pin
58	43	VDDA	I/O	Output of the Regulated Voltage Power/ Power Source of the Analog Circuit
59	44	RLCD	I	Connect Point of Adjust Resistance of the LCD Driver Voltage
60		NC		Empty Pin
61	45	XIN	I	Oscillator Connect Point
62	46	XOUT	O	Oscillator Connect Point
63		NC		Empty Pin
64	47	TXD	O	PWR CTR (See Note 4 in Page 12)
65		NC		Empty Pin
66	48	SEG14	O	Segment 14
67	49	SEG13	O	Segment 13
68	50	SEG12	O	Segment 12
69	51	SEG11	O	Segment 11
70	52	SEG10	O	Segment 10
71	53	SEG9	O	Segment 9
72	54	SEG8	O	Segment 8
73	55	SEG7	O	Segment 7
74	56	SEG6	O	Segment 6
75	57	SEG5	O	Segment 5

76	58	SEG4	O	Segment 4
77	59	SEG3	O	Segment 3
78	60	SEG2	O	Segment 2
79	61	SEG1	O	Segment 1
80	62	COM1	O	Backplane 1 of LCD Display
81	63	COM2	O	Backplane 2 of LCD Display
82	64	COM3	O	Backplane 3 of LCD Display
83	65	COM4	O	Backplane 4 of LCD Display
84	66	ENTX	I	Not Used
85	67	BEEPER	O	Beeper Driver Output
86	68	BLOUT	O	Backlight Driver Output
87	69	RST	I	CPU Reset Input
88		NC		Empty Pin
89	70	REFI	I	ADC Reference Voltage Input
90	71	REFO	O	Bandgap Reference Voltage Output
91	72	FTA	O	Positive Output of the ADC Wave Pre-filter
92		NC		Empty Pin
93	73	FTB	I	Positive Input of the ADC Wave Pre-filter
94	74	FTC	I/O	Negative Point of the ADC Wave Pre-filter
95	75	TSTC	I	Test Pin
96	76	OP1N	I	Negative Input of the AC Buffer Operation Amplifier
97		NC		Empty Pin
98	77	OP1O	O	Output of the AC Buffer Operation Amplifier
99		NC		Empty Pin
100	78	OP2P	I	Positive Input of the AC/DC Converter Operation Amplifier

8. Dice Pad Layout & Pad Coordinate

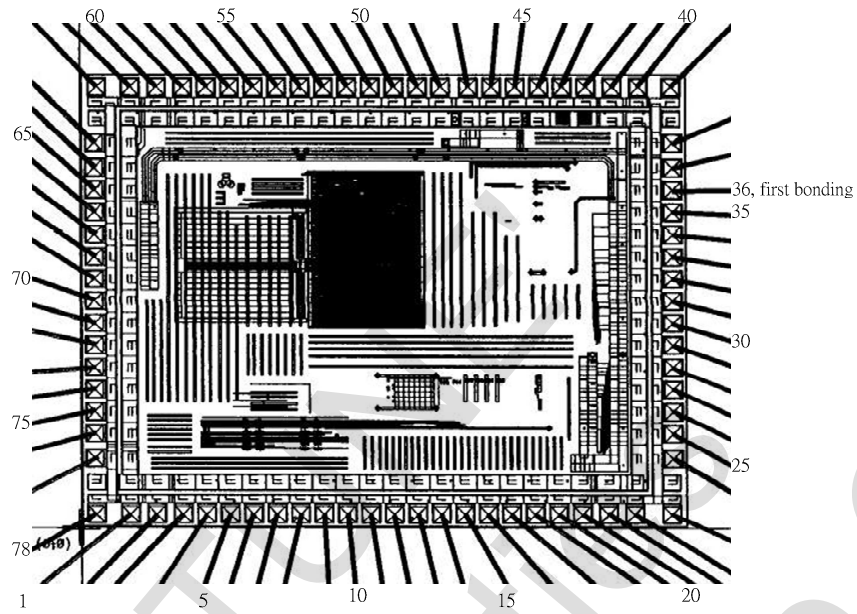

- Substrate should be connected to VSS ◦
- Pad opening: 90μm ◦
- Chip size: 3.24mm×2.58mm ◦

Diagram 3 78PIN Dice

PadNo.	Name	X[mm]	Y[mm]	PadNo.	Name	X[mm]	Y[mm]
1	OP2N	0.264	0.077	40	CB	2.974	2.495
2	OP2O	0.404	0.077	41	CA	2.834	2.495
3	ADIP	0.544	0.077	42	VGG	2.694	2.495
4	ADIN	0.669	0.077	43	VDDA	2.569	2.495
5	SA	0.794	0.077	44	RLCD	2.444	2.495
6	SGND	0.919	0.077	45	XIN	2.319	2.495
7	ADP	1.044	0.077	46	XOUT	2.194	2.495
8	DT	1.169	0.077	47	TXD	2.069	2.495
9	SMV	1.294	0.077	48	SEG14	1.923	2.495
10	CRES1	1.419	0.077	49	SEG13	1.798	2.495
11	RL	1.544	0.077	50	SEG12	1.673	2.495
12	N.C	1.669	0.077	51	SEG11	1.548	2.495
13	RCAP	1.794	0.077	52	SEG10	1.423	2.495
14	ONEK	1.919	0.077	53	SEG9	1.298	2.495
15	TENK	2.044	0.077	54	SEG8	1.173	2.495
16	HUNK	2.169	0.077	55	SEG7	1.048	2.495z
17	ONEM	2.294	0.077	56	SEG6	0.923	2.495
18	TENM	2.419	0.077	57	SEG5	0.798	2.495
19	CRES2	2.544	0.077	58	SEG4	0.673	2.495
20	BLCTR	2.669	0.077	59	SEG3	0.548	2.495
21	ADPC1	2.809	0.077	60	SEG2	0.408	2.495
22	ADPC2	2.949	0.077	61	SEG1	0.268	2.495
23	SELECT	3.147	0.077	62	COM1	0.091	2.495
24	RANGE	3.157	0.396	63	COM2	0.077	2.176
25	REL	3.157	0.536	64	COM3	0.077	2.036
26	HOLD	3.157	0.661	65	COM4	0.077	1.911
27	Hz/DUTY	3.157	0.786	66	ENTX	0.077	1.786
28	CAP	3.157	0.911	67	BEEPER	0.077	1.661
29	MEA4	3.157	1.036	68	BLOUT	0.077	1.536
30	MEA3	3.157	1.161	69	RST	0.077	1.411
31	MEA2	3.157	1.286	70	REFI	0.077	1.286
32	MEA1	3.157	1.411	71	REFO	0.077	1.161
33	LCDC1	3.157	1.536	72	FTA	0.077	1.036
34	LCDC2	3.157	1.661	73	FTB	0.077	0.911
35	TSTA	3.157	1.786	74	FTC	0.077	0.786
36	VSS	3.157	1.911	75	TSTC	0.077	0.661
37	AGND	3.157	2.036	76	OP1N	0.077	0.536
38	VDD	3.157	2.176	77	OP1O	0.077	0.396
39	VB	3.148	2.495	78	OP2P	0.083	0.077

9. Technical Specification (VDD=3V, Ta=25°C)

Symbol	Parameter	Test Condition	Min	Typ	Max	Units
VDD	Recommend Operation Power Voltage		2.4		3.6	V
IDD	Supply Current	At DCV Mode		1.5	2	mA
IPO	Power Supply Current	At Power Off			10	μA
VIH	Digital Input High Voltage		VDD-0.5			V
VIL	Digital Input Low Voltage				0.5	V
Ipu	Pull up Current	Vin=0		5	10	μA
AGND	Analog Ground Voltage		VDD/2 -3%	VDD/ 2	VDD/2 +3%	V
VDDA	Analog Power		3.4	3.7	4	V
VBAND	Build in Reference Voltage	Relative to AGND	1.1	1.25	1.4	V
	Build in Reference Voltage Output Voltage Coefficient	VDD=2.4~3.6	-2000		+2000	ppm/V
REFI	Recommend Reference input Voltage	Relative to AGND		0.44		V
VBATT	Low Battery Detector Voltage		2.25	2.4	2.55	V
FLCD	LCD Frame Frequency			32		Hz
VLCD	LCD Pk-Pk Driver Voltage		2.8	3	3.2	V
FBEEP	Beeper Frequency			2.7		kHz
FRS232	RS232 Baud Rate			2400		bitHz
IRSOUT	RS232 Output High Current	VOH=2V	2			mA
	Zero Input Reading	DC ADPxl Input=0V	-0.001	0.000	0.001	
	Linearity (Max. Deviation From Best Straight Line Fit)	DC ADPxl Input,Full Scal±240.0mV	-1	0	+1	Counts
	AC Measurement Bandwidth Error	AC ADPxl Input240mVrms 20Hz~1kHz			0.2	%
Rcc	Continuity Check Value		10		60	Ohm
	ADC Measurement O.L Display Count			4050		Counts
	Autorange Up Counts			4000		Counts
	Autorange Down Counts			360		Counts
VFREA	Frequency Counter Input Level (Hz/Duty Control)	VIL(Relative to AGND)	-60			mV
		VIH(Relative to AGND)			60	mV
FMAXA	Frequency Counter Max Input frequency (Hz/Duty Control)	Vpp=±100mV Square Wave Input	500k			Hz
*1	Duty Measurement Min Pulse Width Error (Hz/Duty Control)	Vpp=±100mV Square Wave Input			1	μS
VFRED	Frequency Counter Input Level (MEAS=0101)	VIL(Relative to AGND)	-600			mV
		VIH(Relative to AGND)			600	mV
FMAXD	Frequency Counter Input Level (MEAS=0101)	Vpp=±600mV Square Wave Input	5M			Hz
*1	Duty Measurement Min Pulse Width Error(MEAS=0101)	Vpp=±600mV Square Wave Input			100	nS
	Capacitor Measurement Accuracy after Zero Input Relative	5.120nF Mode			5%+25	Counts
		51.20 nF Mode			2%+10	Counts
		512.0 nF Mode			0.5%+3	Counts

	To Adjust by 512.0nF Mode	5.120 μ F Mode			1%+2	Counts
		51.20 μ F Mode			1.5%+2	Counts

*1 In the duty cycle measurement, we have to input square waves. The main error of the measurement is due to the error of the pulse width that the comparator can resolve. Suppose the error is 100ns and the input frequency is 100KHz. We can divide the square wave into 1000 segments (1000 counts), and thus each count takes 10 ns. Therefore the maximum error in Duty Cycle measurement is (100ns/10ns)=10 Counts. 50% duty cycle signal can be measured to 50.0%±1.0%. The signal may not be measured if the duty cycle is more than 99% or less than 1%, and the measurement will display 0.00%.

FORTUNE
 Properties
 For Reference Only

10. Measurement Mode Selection

10.1 Auto Measurement Mode Selection (MEA1~MEA4 is “1” for empty, and “0” for connect to VSS;^①):

ME A 4	ME A 3	ME A 2	ME A 1	Measurement Function and Select Key Function Switch	Hz/Duty	Rel	Range	Hold	Select	Jump ^①
0	0	0	1	DCV	V/Hz/ Duty Switch	•	•	•		J5
0	0	1	0	ACV ^②	V/Hz/Duty Switch	•	•	•		J5
0	1	0	0	Hz/Duty	Hz/Duty Switch			•		J7, J9
0	1	1	1	DC μ A/AC μ A Switch	μ A/Hz/Duty Switch	•	•	•	•	J3, J11
1	0	0	0	ACV/DCV ^③ Switch	V/Hz/Duty Switch	•	•	•	•	J5
1	0	1	0	ACA/DCA Switch	A/Hz/Duty Switch	•	•	•	•	J3
1	0	1	1	DCmA/ACmA Switch	mA/Hz/Duty Switch	•	•	•	•	J3, J10
0	1	0	1	Cap		•	•	•		J4, J6
0	1	1	0	Diode continuity Switch					•	J4, J6
1	0	0	1	Ohm/Diode/Cap/Continuity Switch		•	Ohm•	•	•	J4, J6
0	0	1	1	Ohm		•	•	•		J4, J6
1	1	0	0	Diode						J4, J6
1	1	0	1	Continuity						J4, J6
1	1	1	0	hFE, ^④		•		•		J8
1	1	1	1	Temp. ^⑤		•		•		J1, J2,

Note: ^① The “JX” in Jump column means the JX of the measurement function is open circuit in the diagram that common used by diagram 6 and 7.

^② In Auto mode, the mV Measurement of ACV mode can be selected only when the Range key is pressed.

^③ It input from ADP. The full measurement is 400mV, and no decimal.

^④ It input from TSTC. The amplification of the OP is set to about 2.5 times.

^⑤ In auto measurement mode, CAP, LCDC1 and LCDC2 are empty.

10.2 Manual Measurement Mode Selection (MEA1~MEA4, CAP is “1” for empty, and “0” for connect to VSS)

CAP	MEA4	MEA3	MEA2	MEA1	Function	Jumper	Select	Rel	Hz/Duty	Hold
0	0	0	0	1	400.0mV	J5	DC/AC	●	●	●
0	0	0	1	0	4.000V	J5	DC/AC	●	●	●
0	0	0	1	1	40.00V	J5	DC/AC	●	●	●
0	0	1	0	0	400.0V	J5	DC/AC	●	●	●
0	0	1	0	1	1000V	J5	DC/AC	●	●	●
0	0	1	1	1	Beeper	J4,J6				
0	1	0	0	1	400.0Ω	J4,J6		●		●
0	1	0	1	0	4.000kΩ	J4,J6		●		●
0	1	0	1	1	40.00kΩ	J4,J6		●		●
0	1	1	0	0	400.0kΩ	J4,J6		●		●
0	1	1	0	1	4.000MΩ	J4,J6		●		●
0	1	1	1	0	40.00MΩ	J4,J6		●		●
0	1	1	1	1	Diode	J4,J6				
1	0	0	0	1	4.000nF	J4,J6		●		●
1	0	0	1	0	40.00nF	J4,J6		●		●
1	0	0	1	1	400.0nF	J4,J6		●		●
1	0	1	0	0	4.000μF	J4,J6		●		●
1	0	1	0	1	40.00μF	J4,J6		●		●
1	0	1	1	0	200.0μF	J4,J6		●		●
1	0	1	1	1	hFE	J8				●
1	1	0	0	0	10.00A	J3	DC/AC	●	●	●
1	1	0	0	1	400.0mA	J3,J10	DC/AC	●	●	●
1	1	0	1	0	40.00mA	J3,J10	DC/AC	●	●	●
1	1	0	1	1	4000μA	J3,J11	DC/AC	●	●	●
1	1	1	0	0	400.0μA	J3,J11	DC/AC	●	●	●
1	1	1	0	1	Duty	J7,J9			●	●
1	1	1	1	0	Hz	J7,J9			●	●
1	1	1	1	1	°C	J1,J2		●		●

- Notes: 1. The following pin numbers are dice package numbers.
 2. The “JX” in the form means it is connected in the common use diagram.
 3. LCDC1 (pin33) connects to VSS.
 4. PWR CTR: TXD (pin47).
 Power On is “1”; Power Off is “0”. Provide the power control of external active components.
 5. 400.0mV is input singly from ADP(pin7) so that makes the specification be better.
 6. hFE is input 400.0mV from ADP(pin7) and AGND.
 7. Temp. is input 40μV/°C from TSTC(pin75) and AGND.
 8. The difference between manual measurement and auto measurement:
 ① CAP(pin28) pin and MEA4~MEA1 are used together for select.
 ② LCDC1(pin33) connects to VSS.
 ③ mV single mode is input from ADP.
 Key control pins: HOLD: pin26; Rel: pin25; Select: pin23; Back Light: pin20; Back light Output: pin68.

11. Keys Definition

11.1 Range (Auto/Manual Measurement Switch)

Range key is the key to switch Auto/Manual Measurement and it acts in activation. The default is Auto Measurement when power is on. To press one time, the system will switch to Manual Measurement. In Manual Measurement mode, the system will jump one range up when the key is pressed one time. If continue to press the key in the top range, the system will jump to the lowest range, and recircle orderly. If press and hold the key over 2 seconds, the system will switch to Auto Measurement mode. The Hz/Duty Cycle cannot be measured by Manual Measurement.

11.2 Hold (Display Hold)

Hold key is the key to control Display Hold and it acts in activation. The functions are: hold the display data. When the key is pressed, the display data will be locked and keep unchanged; if press the key again, the system will be unlocked and enter the normal measurement mode.

11.3 Rel (Relative Value Measurement)

Rel key is the key to measure Relative Value and it acts in activation. All controls can measure Relative Value except Hz/Duty, Diode and Continuity functions.

11.4 BLCTR (Backlight Control)

BLCTR key is the key to control Backlight and it acts in activation. When press and hold the key over 2 seconds will enable Backlight; press the key again, Backlight will disable.

11.5 Select (Function Switch)

Select is the key to select the functions and it acts in activation. Use the key to select the function to measure.

11.6 Hz/Duty (Frequency/Duty Cycle)

Hz/Duty is the key to select Frequency/Duty Cycle and it acts in activation. In Frequency Measurement Mode, press the key is to select Hz or Duty Measurement; in AC/DC Mode, press the key is to select Voltage /Hz/Duty or Current/Hz/Duty Measurement Mode.

11.7 Reset (Reset Key)

Reset is the key to reset the system and it acts in activation. Press the key is to reset the microprocessor.

12. Other Functions

12.1 Auto Power-off

In the process of measurement, if no any action is operated in 30 minutes for function keys or function switch, the meter will be "Auto Power-Off" (Standby Mode). In Auto Power-Off status, if the function keys are pressed or the function switch is activated, the meter will be "Auto Power-On" (Working Mode).

If press and hold Select key to power on, Auto Power-Off function will be disabled.

12.2 Buzzer

When press any key or turn any function switch, the buzzer will raise one sound (approx. 0.25 second ~ 1 second). When measuring AC Voltage > 750V, DC Voltage > 1000V, AC/DC mA Current > 4000 μ A, AC/DC μ A Current > 400.0mA, AC/DC Large Current > 10A, the buzzer will keep sounding as the overload warning. Approximate 1 minute before the system is auto power off, the buzzer will raise constantly 5 sounds to warning. Before the system is power off, the buzzer will raise 1 long sound to warning.

12.3 Backlight

The system has the Backlight driver output function to control the Backlight circuit open and close so as to provide the convenience of reading the value when in the dim light and poor vision. When press the BLCTR key over 2 seconds, Backlight will open; when press

the key again, Backlight will close. After Backlight is open, if the key is not pressed, it will extinguish after 15 seconds.

12.4 ADPC1/ADPC2 Functions

ADPC	function	Status	Description
ADPC1	SelectCurrent Measurement mode	Open (1)	$\mu\text{A}/\text{mA}/\text{A}$ Sampling Resistance is $1\text{k}\Omega/10\Omega/0.01\Omega$
		Connect to VSS (0)	$\mu\text{A}/\text{mA}/\text{A}$ Sampling Resistance is $100\Omega/1\Omega/0.01\Omega$
ADPC2	Select DC/AC Status	Open (1)	When power on, it's DC status
		Connect to VSS (0)	When power on, it's AC status

13. LCD Display

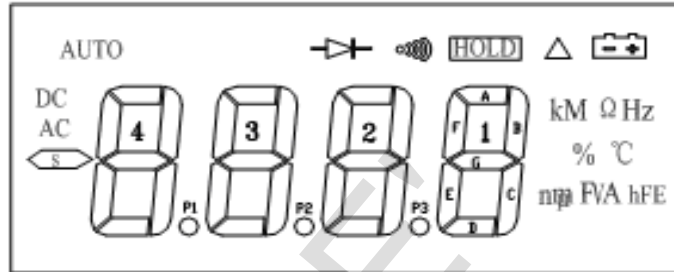

FS9711 LP1/FS9721 LP1 LCD DISPLAY AND FORMAT

PIN	1	2	3	4	5	6	7	8	9	10	11	12	13	14	15	16	17	18
COM	COM4	COM0	COM2	COM1	SEG1	SEG2	SEG3	SEG4	SEG5	SEG6	SEG7	SEG8	SEG9	SEG10	SEG11	SEG12	SEG13	SEG14
COM1			COM1		A1	A4	A3	A3	A2	A2	A1	A1	←	→	△	□		
COM2		COM2		A0	A4	A4	A3	A3	A2	A2	A1	A1	←	→	△	□	Az	hFE
COM3		COM3		AC	A4	A4	A3	A3	A2	A2	A1	A1	←	→	△	□	V	°C
COM4	COM4			AC	→	A4	A1	A3	A2	A2	A1	A1	←	→	△	□	F	Ω

- Notes: 1. Working Voltage: 3V.
- 2. Drive Method: 1/4 Duty, 1/3 Bias.

Diagram 4 LCD Display Structure

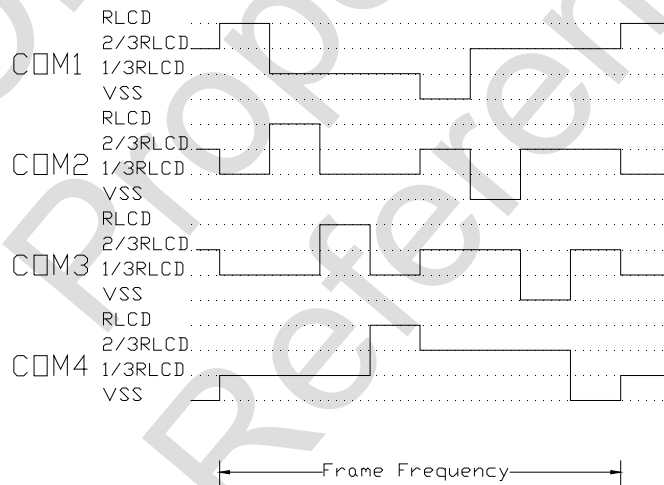
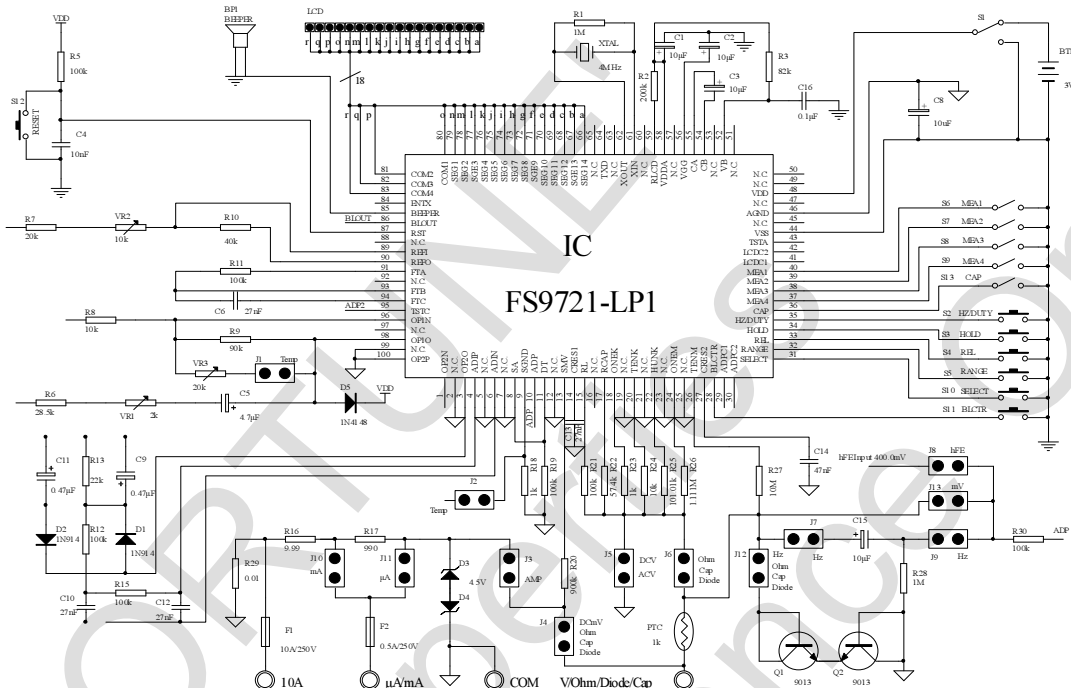

Diagram 5 LCD Display COM Drive Wave

14. Application Description

14.1 Common Use Circuit Diagram
 A. 100 PIN Package IC



- VSS Battery Negative Terminal and IC Negative Power Input
- VDD Battery Positive Terminal and IC Positive Power Input
- VGG VDD Charge Pump voltage about 2*VDD
- VDDA IC Analog Power about 3.9V
- AGND Analog Common about VDD/2

Diagram 6 100 PIN Common Use Circuit Diagram

B. 78 PIN Dice IC

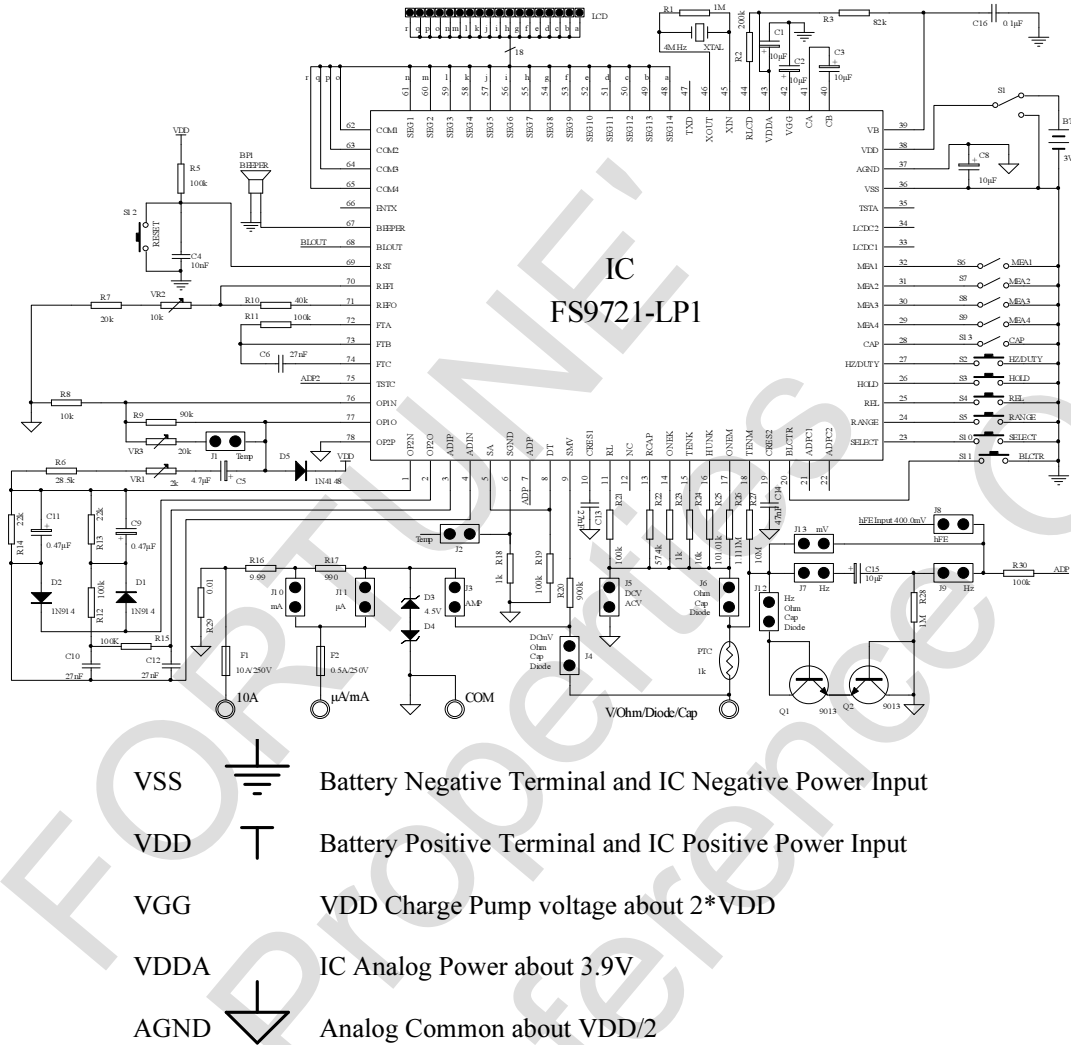

- VSS Battery Negative Terminal and IC Negative Power Input
- VDD Battery Positive Terminal and IC Positive Power Input
- VGG VDD Charge Pump voltage about 2*VDD
- VDDA IC Analog Power about 3.9V
- AGND Analog Common about VDD/2

Diagram 7 78 PIN Common Use Circuit Diagram

14.2 FS9721_LP1 Technical Pointer and Components Relationship

	Network	Current Mode/10 (R20:R19=9:1)	AC Measurement (R6+VR1,R13=R14)	Voltage Reference (R10,R7,VR2)
DC 400mV	R27	No	No	Yes
DC 4V	$R26/(R27+R26)=1/10$	No	No	Yes
DC 40V	$R25/(R27+R25)=1/100$	No	No	Yes
DC 400V	$R24/(R27+R24)=1/1000$	No	No	Yes
DC 1000V	$R23/(R27+R23)=1/10000$	No	No	Yes
AC 400mV	$R26/(R27+R26)=1/10$, R9:R8=9:1	No	Yes	Yes
AC 4V	$R26/(R27+R26)=1/10$	No	Yes	Yes
AC 40V	$R25/(R27+R25)=1/100$	No	Yes	Yes
AC 400V	$R24/(R27+R24)=1/1000$	No	Yes	Yes
AC 1000V	$R23/(R27+R23)=1/10000$	No	Yes	Yes
R 400Ω	$R27//R23=1kΩ$	No	No	No
R 4kΩ	$R27//R23=1kΩ$	No	No	No
R 40kΩ	$R27//R24=10kΩ$	No	No	No
R 400kΩ	$R27//R25=100kΩ$	No	No	No
R 4MΩ	$R27//R26=1MΩ$	No	No	No
R 40MΩ	$R27=10MΩ$	No	No	No
DC 400μA	$R16+R17+R29=1kΩ$	No	No	Yes
DC 4000μA	$R16+R17+R29=1kΩ$	Yes	No	Yes
DC 40mA	$R29+R16=10Ω$	No	No	Yes
DC 400mA	$R29+R16=10Ω$	Yes	No	Yes
DC 10A	$R29=0.01Ω$	No	No	Yes
AC 400μA	$R16+R17+R29=1kΩ$	No	Yes	Yes
AC 4000μA	$R16+R17+R29=1kΩ$	Yes	Yes	Yes
AC 40mA	$R29+R16=10Ω$	No	Yes	Yes
AC 400mA	$R29+R16=10Ω$	Yes	Yes	Yes
AC 10A	$R29=0.01Ω$	No	Yes	Yes
CAP	R22	No	No	No
Diode		No	No	Yes

14.3 FS9721_LP1 (Diagram 6 and Diagram 7) Components List

NO.	SPEC.	NO.	SPEC.	NO.	SPEC.	NO.	SPEC.	NO.	SPEC.
R1	1MΩ	R13	22kΩ	R25	101.010kΩ	C7	10μF	VR2	10kΩ
R2	200kΩ	R14	22kΩ	R26	1.111MΩ	C8	10μF	VR3	10kΩ
R3	82kΩ	R15	100kΩ	R27	10.000MΩ	C9	0.47nF	LCD	LCD
C16	0.1μF	R16	9.99Ω	R28	1MΩ	C10	27nF	XTAL	4MHz
R5	100kΩ	R17	990Ω	R29	0.01Ω	C11	0.47nF	IC	FS9721_LP1
R6	28.5kΩ	R18	1kΩ	R30	100kΩ	C12	27nF	Battery	1.5V×2
R7	20kΩ	R19	100kΩ	C1	10μF	C13	27nF	BP1	Buzzer
R8	10kΩ	R20	900kΩ	C2	10μF	C14	47nF	PTC	1kΩ
R9	90kΩ	R21	100kΩ	C3	10μF	C15	10μF		
R10	40kΩ	R22	57.4kΩ	C4	10nF	D1	1N914		
R11	100kΩ	R23	1.001kΩ	C5	4.7μF	D2	1N914		
R12	100kΩ	R24	10.010kΩ	C6	27nF	VR1	2kΩ		

14.4 Power System

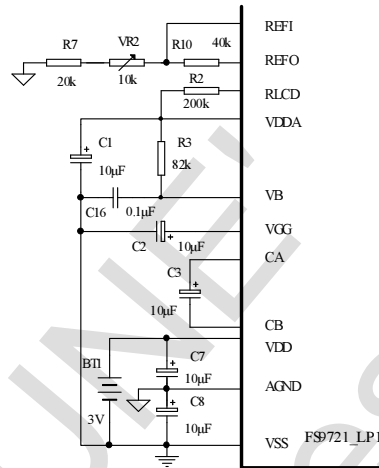

Diagram 8 Power Circuit

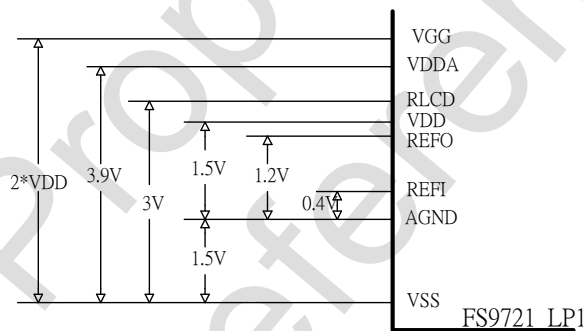

Diagram 9 Relative Voltage of Each Point

VB is the bias current input point in IC. The increase of R3 will reduce the current consumption in IC, but the shortage of bias current will affect the input range of AC measurement.

AGND is the analog ground connection. Its value is equal to the middle point of battery voltage. The point value is generated in the IC and cannot connect to the middle point of battery.

C7 and C8 are bypath capacitance, and also to make AGND regulated to VDD and VSS. C3 is power pump capacitance. IC makes VDD voltage pass C3 to charge/discharge to rise VGG being about double voltage of VDD.

VDDA is the output voltage after the regulation of VGG in the IC. It is about 3.9V that relative to VSS.

REFO is the bandgap power source in the IC. It is about 1.2V that relative to AGND and has 100ppm/°C stability.

14.5 Power Supply Circuit

The different applications of user make different power supply methods. In some measurements, sensor requires higher voltage such as OPAMP, Hale components and so on that it is difficult to supply the power by 3V, then you can take some power supply methods as below.

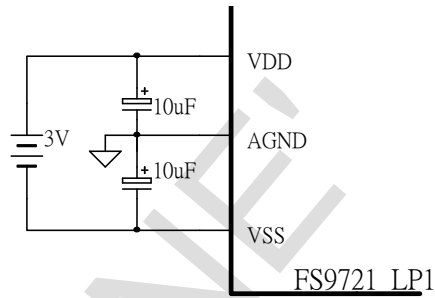

Diagram 10 3V Power Supply

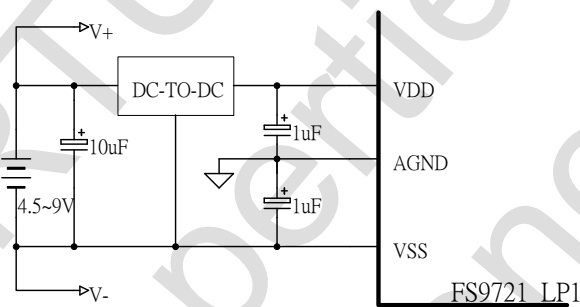

Diagram 11 4.5V~9V Power Supply

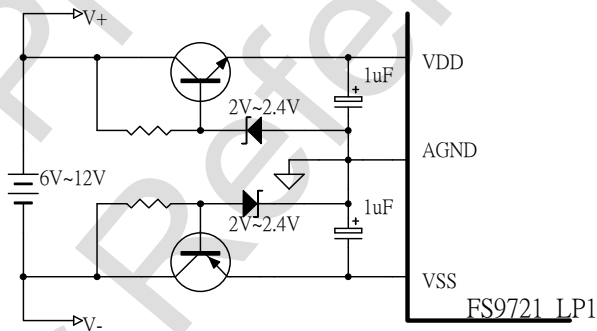

Diagram 12 6V~12V Power Supply

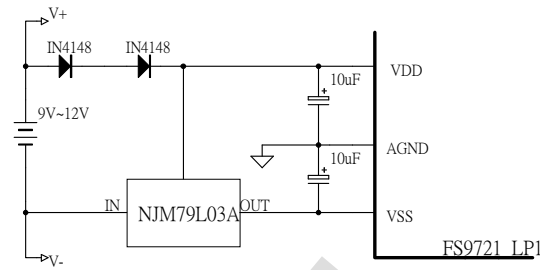

Diagram 13 9V~12V Power Supply

14.6 Basic Power Source

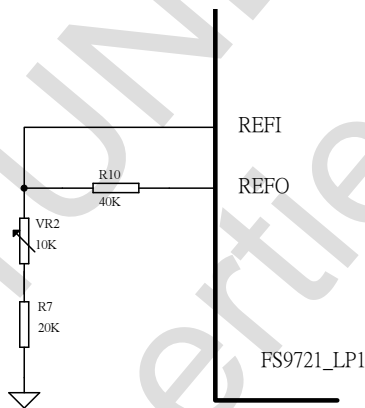

Diagram 14 Utility of Internal Basic Power Source

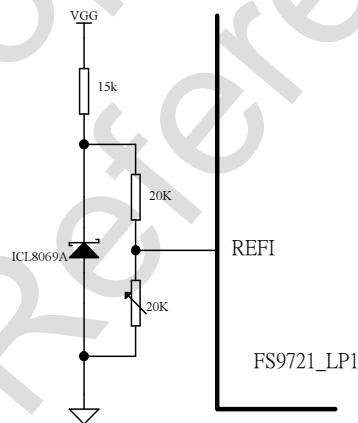

Diagram 15 Utility of External Basic Power Source

14.7 Activated Reset Circuit

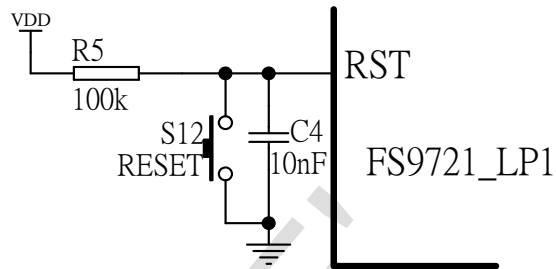

Diagram 16 Reset Circuit

14.8 Crystal Oscillator Circuit

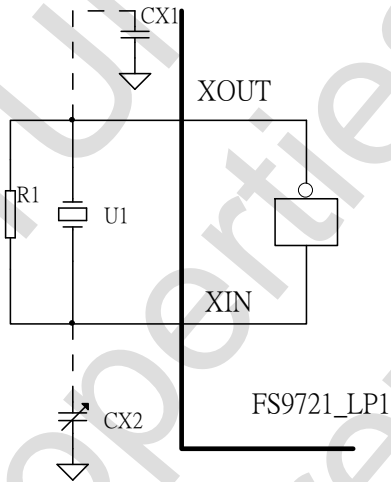

Diagram 17 Crystal Oscillator Circuit

In the diagram, R1 provides the static working point for the revisor; CX2 is for tiny adjustment of frequency; CX1 is temperature compensation. In less requirements situation, CX1 and CX2 can be unused.

Mode Switch and Function Control Circuit

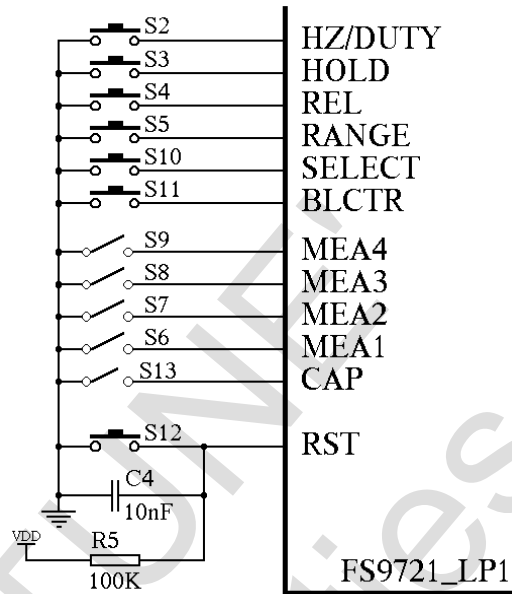

Diagram 20 Mode Switch and Function Control Circuit

S6~S9 and S13 are mode switches in lock. For their functions, please refer to 10.1 and 10.2. S2~S5 and S10~S11 are function selection switches in activation. For their functions, please refer to “Keys Definition” and “Other Functions”.

In actual application, the utility of switch and keys should be taken according to the real situation.

14.11 AC Commutation Circuit

Diagram 21 is the average commutation circuit diagram of FS9711B. In the circuit, AC signals enter IC through R26, and then in the process of voltage division through R26, R25, R24, R23 and R22. The divided AC signals are out from OP10 pin and enter IC through ADIP pin and ADIN pin after commutation. VR2 can adjust the voltage of the signals to do the calibration of AC measurement.

240mV mode is amplified 10 times through OP.

Diagram 22 is the peak commutation circuit diagram. Diagram 23 is the true validity commutation circuit diagram, the user can determine by self according to the need to select which commutation circuit.

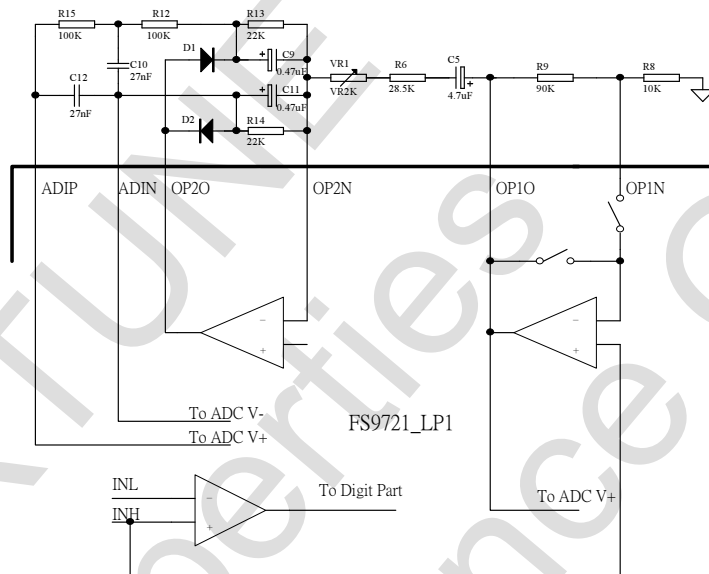

Diagram 21 Average Commutation Circuit Diagram

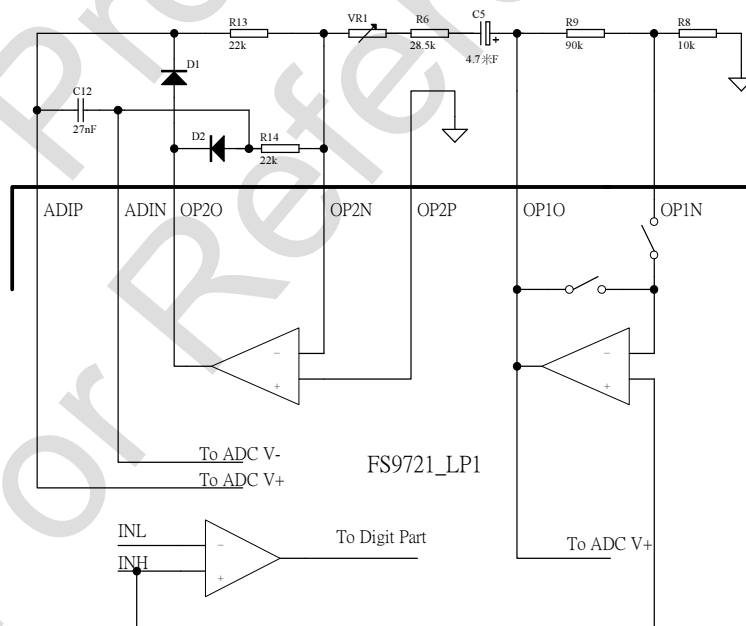

Diagram 22 Peak Commutation Circuit

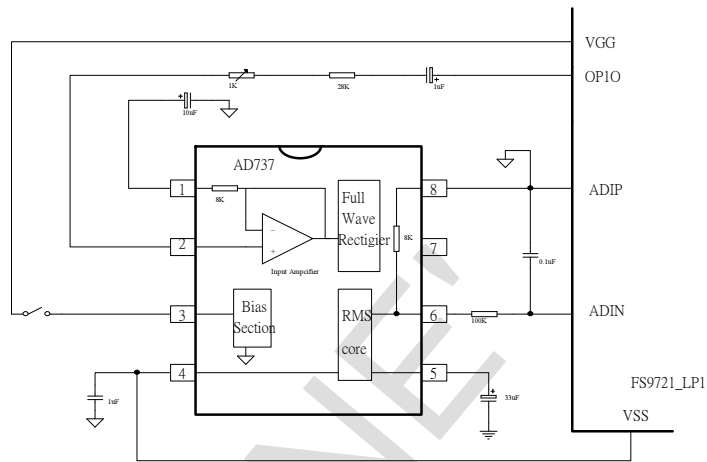

Diagram 23 True Validity Commutation Circuit

14.12 Voltage Measurement

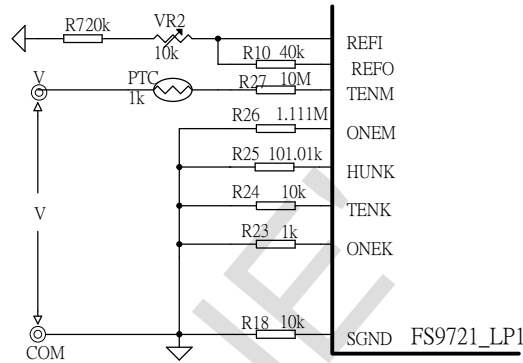

Diagram 24 Voltage Measurement

When doing the voltage measurement, the measuring voltage is input from resistance R27, and DCmV is not divided, but enter IC directly; 4V, 40V, 400V, 1000V mode is divided by R26, R25, R24, R23 and R27 to gain 1/10, 1/100, 1/1000, 1/10000 voltage, then enter IC. To adjust the resistance value of VR2 can do the calibration of measurement.

Voltage Division of Voltage Measurement Diagram is as below:

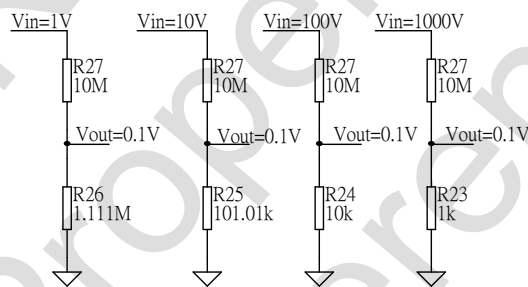

Diagram 25 Voltage Division Circuit Diagram

The formula of voltage division is:

$$V_{out} = V_{in} \times [R_s / (R_{27} + R_s)]$$

Rs is R26, R25, R24 or R23

Therefore, the accuracy of R23, R24, R25, R26 and R27 determine the accuracy of the measurement.

AcmV enter IC through R27 and is divided by R26 and R27 to get 1/10 voltage, then is amplified 10 times internal to fulfill the measurement, so the accuracy of R9 and R8 is also determine the measuring accuracy of ACmV.

14.13 Current Measurement

The difference between Current Measurement (A) and Current Measurement (B) is as follow:

Mode	Current Measurement (A)		Current Measurement (B)	
	ADPC1 Open		ADPC1 connects to VSS	
	Measurement	Sampling Resistance	Measurement	Sampling Resistance
A	40A	0.01Ω	40A 4A	0.01Ω
mA	400mA 40mA	10Ω	400mA 40mA	1Ω
μA	4000μA 400μA	1kΩ	4000μA 400μA	100Ω
Max. Voltage Reduction	4V		0.4V	

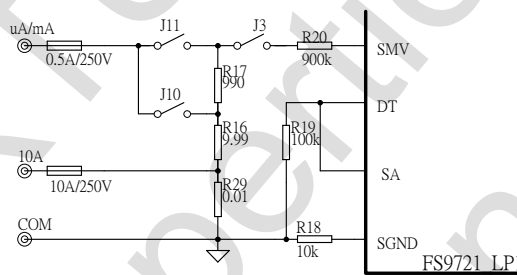

Diagram 26 Current Measurement(A)

In TSTB open mode, the current signal enters IC from R20.

When doing the current measurement, The sampling resistance of μA mode is (R16+R17+R29), the sampling resistance of mA mode is (R16+R29) and the sampling resistance of 10A mode is R29. They are measured respectively through the mode switch. When measuring μA, J10 is open, J11 and J3 is close; when measuring mA, J11 is open, J10 and J3 is close; when measuring the large current by using 10A mode, J3 is close.

The maximum reduced voltage for μA, mA and 10A modes is 4V. These voltages are input voltage comparator to compare. If the voltage is smaller than 400mV, the current signal is sent directly to the A/D converter; if the voltage is larger than 400mV, the system will jump up one mode and divide the voltage by R20 and R19, then send its 1/10 to the A/D converter.

The accuracy of resistor R16, R17, R29, R19 and R20 influence the accuracy of the current measurement.

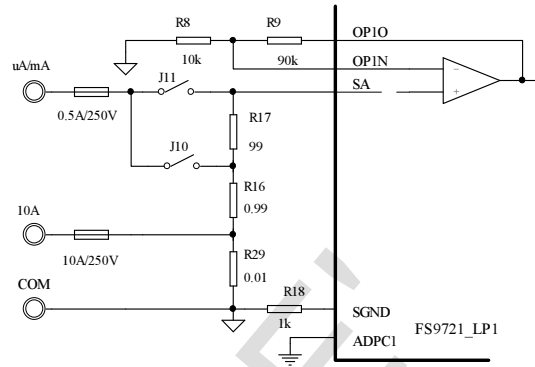

Diagram 27 Current Measurement(B)

In TSTB connecting to VSS mode, the current signal enters IC from SA.

When doing the current measurement, The sampling resistance of μA mode is $R16+R17+R29$, the sampling resistance of mA mode is $R16+R29$, and the sampling resistance of 10A mode is $R29$. They are measured respectively through the mode switch. When measuring μA , J10 is open and J11 is close; when measuring mA, J11 is open and J10 is close; the large current enters directly via 10A port.

The maximum reduced voltage for μA , mA and 10A modes is 0.4V.

These voltages are input voltage comparator to compare. If the voltage is smaller than 40mV, it will be sent to $\times 10$ times amplifier to amplify, then sent to A/D converter; if the voltage is larger than 40mV, the system will work the auto-ranging signal, and jump up one mode under the control of microprocessor and send the current signal directly to the A/D converter.

The accuracy of resistance $R16$, $R17$, $R29$, $R8$ and $R9$ affects the accuracy of the current measurement.

14.14 Resistance Measurement

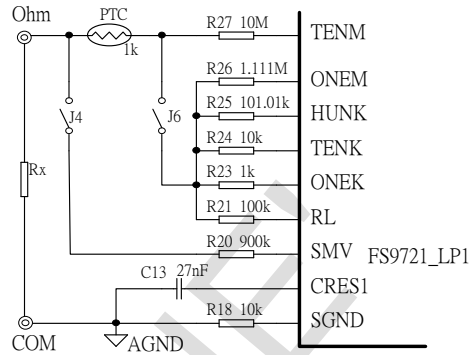

Diagram 28 Resistance Measurement

Resistance measurement refers to standard resistance, and then takes a comparison between measuring resistance and standard resistance to get the measuring resistance value. The standard resistance of 40MΩ mode is 10MΩ (R27). The standard resistance of other modes are to parallel respectively R27 and R26, R25, R24, R23 to get 1MΩ, 100kΩ, 10kΩ, 1kΩ resistance. When doing resistance measurement, internal IC will generate 0.4V voltage (relative to AGND), the voltage is output respectively to measuring resistance through resistance R27 and R26, R25, R24, R23. R21 connects to RL. It is the negative end through the standard resistance to get the voltage reference. J4 and J6 are mode switch. When doing resistance measurement, J4 and J6 are close.

C13 is the wave filter capacitance of measuring point in resistance measurement.

14.15 Diode Test

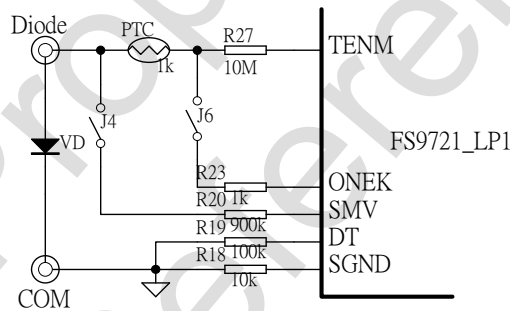

Diagram 29 Diode Measurement

Diode test is to generate 1.5V voltage from internal IC and output through R23, then add to the positive of diode through PTC. The positive voltage reduction V_D generated by diode is about 0.5V-0.7V. V_D is divided by R20 and R19, and get $1/10 V_D$, then is amplified 10 times by internal OP to display V_D value. J4 and J6 are mode switch. When doing diode measurement, J4 and J6 are close.

14.16 Short Circuit Testing

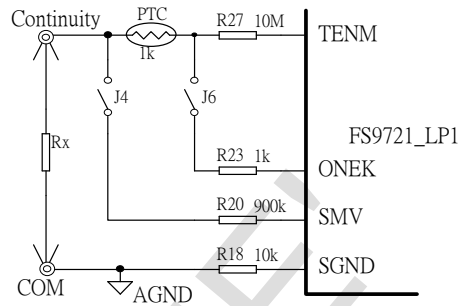
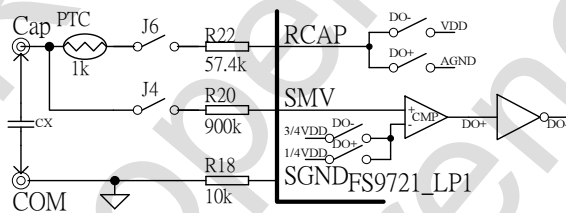

Diagram 30 Short Circuit Testing

Short circuit testing is proceeded in 400Ωresistance mode. 0.4V voltage (relative to AGND) is generated by internal IC and output through R23, then add to short measuring point through PTC. J4 and J6 are mode switch and are close during doing short circuit testing. Rx gets voltage V_{Rx} , and input IC through R20. If Rx smaller than 50Ω, the beeper will sound.

14.17 Capacitance Measurement



Typical Wave of Input End

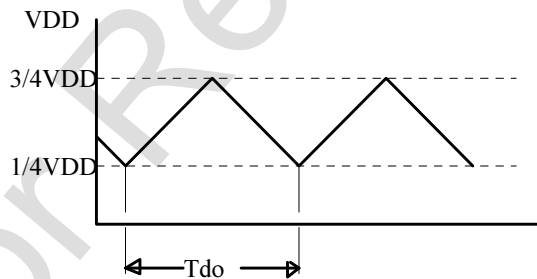

Diagram 31 Capacitance Measurement

Capacitance measurement is to charge/discharge to measuring capacitance through R22 to form an oscillation, then calculate the cycle of oscillation to get the capacitance value. To adjust R22 can calibrate the value in capacitance measurement. J4 and J6 are mode switches. When doing capacitance measurement, J4 and J6 are close.

(In actual application, if the linearity is worse when doing 5.120nF measurement, you can take a consideration of paralleling a proximate 1000pF capacitance in input end of capacitance measurement during design. When doing the measurement, to press REL key and make the value be zero before measuring. The linearity of the smaller measurement in capacitance mode will be better.)

14.18 Frequency Measurement

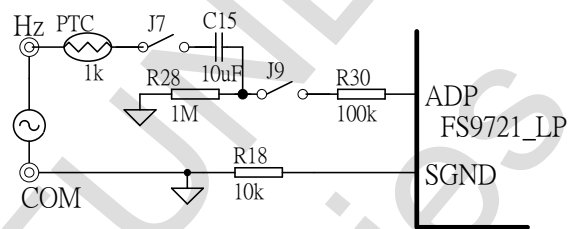

Diagram 32 Frequency Measurement

14.19 Triode hFE Testing

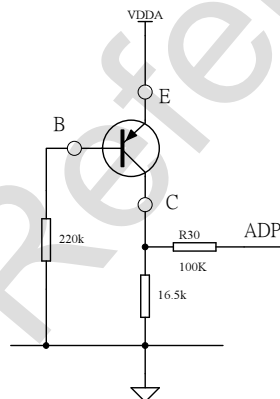

Diagram 33 PNP-type Triode

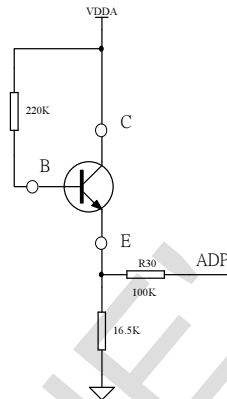

Diagram 34 NPN-type Triode

14.20 Temperature Measurement

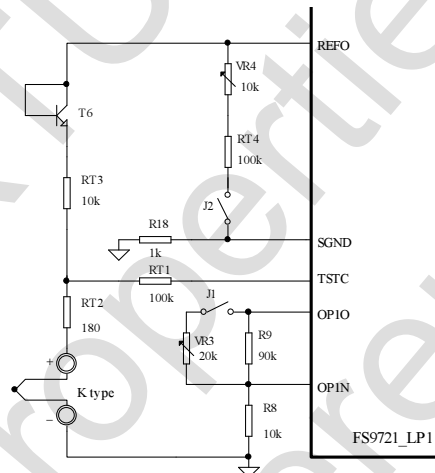

Diagram 35 Temperature Measurement (1)

For the connection of the thermocouple in the diagram, the negative (-) point can be connected directly to the ground (AGND). When the thermocouple is not connected or damaged, it will display overload (OL).

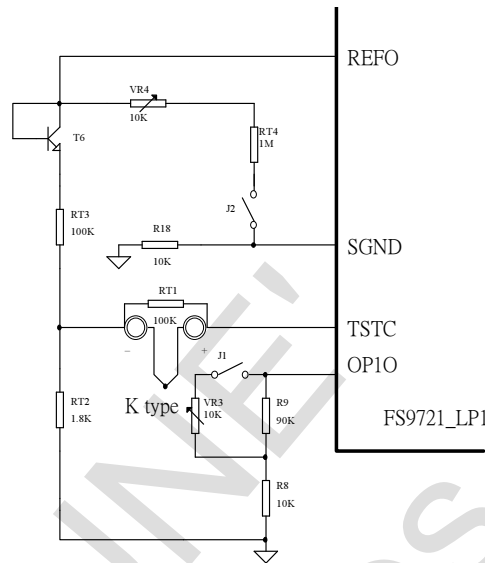

Diagram 36 Temperature Measurement (2)

In the diagram, the connection of the thermocouple is more troublesome, but when the thermocouple is not connected or damaged, it will display the indoor temperature.

1. In these figures, the Bipolar (T6) is used as a Diode. Since the VBE voltage of T6 decreases by 2~2.5mV as the ambient temperature increases per 1 degree C, this characteristic is used for cold junction compensation. Something to be addressed here is that:

Since the bandgap voltage is varied upon every single IC chips, and the model used for T6 is different, so ($\Delta V / ^\circ\text{C}$) is also different, therefore, the cold junction compensation is different on each IC. So the RT1, RT2, RT3 and RT4 need to be adjusted properly.

2. The resistor VR4 in Figure 35 and Figure 36 is used to achieve the calibration at 0 degree C, while VR3 is used to achieve the calibration at the high temperature (such as 100 degree C). Since the temperature coefficient of the externally connected K-type thermocouple is 40uV/ $^\circ\text{C}$, we can adjust VR3 so that the amplification of the OP is set to about 2.5 times.

3. Please note the following 2 aspects when using Figure 35:

1. Because the internal impedance of K-type thermocouple might affect the compensation voltage, we can change RT2 and RT3 to 1.8K and 100K accordingly to minimize the influence.

2. When using voltage calibration, because of the calibrator's internal impedance, it causes the non-accuracy on calibration. Therefore, the best way to do this measurement is to input the voltage directly across RT1. In other words, the positive voltage is connected to TSTC, and the negative end is connected to the intersection of RT1 and RT2.

15. Package Outline

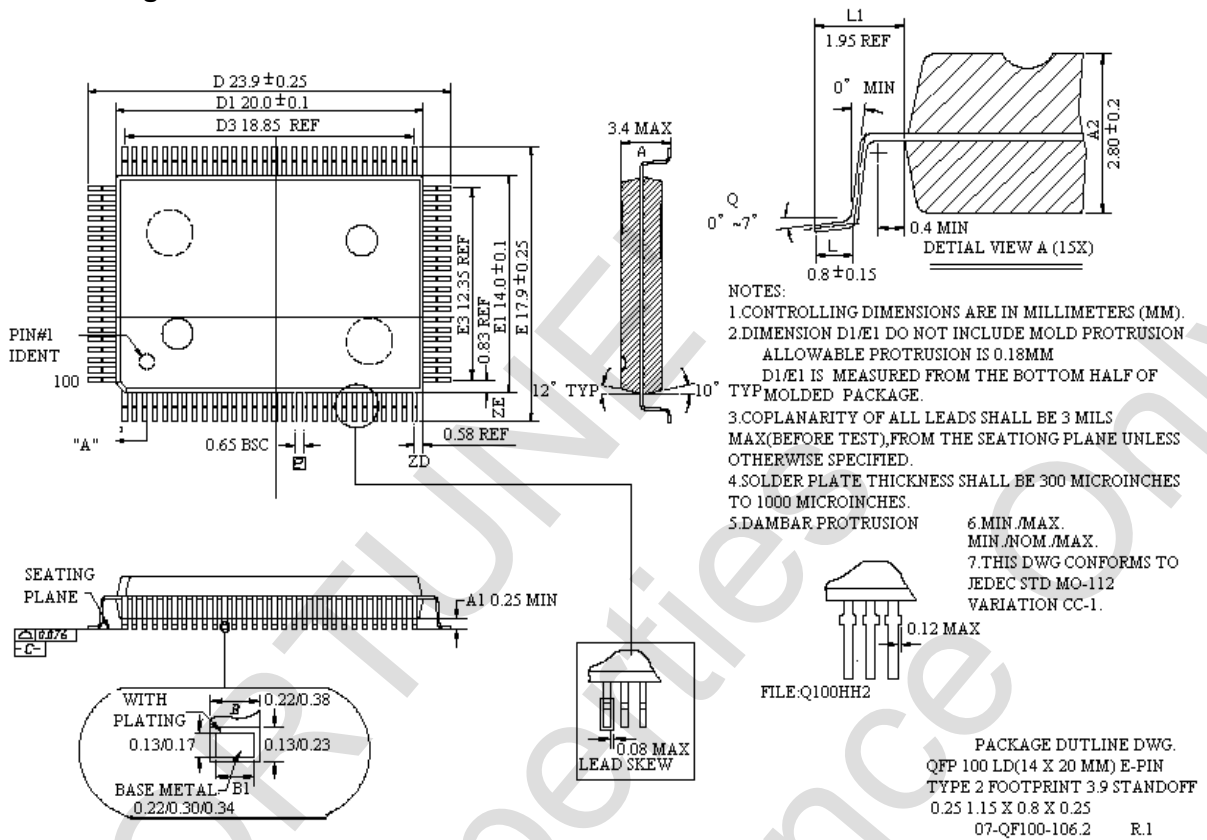

Diagram 37 Package Outline

16. Demo Board

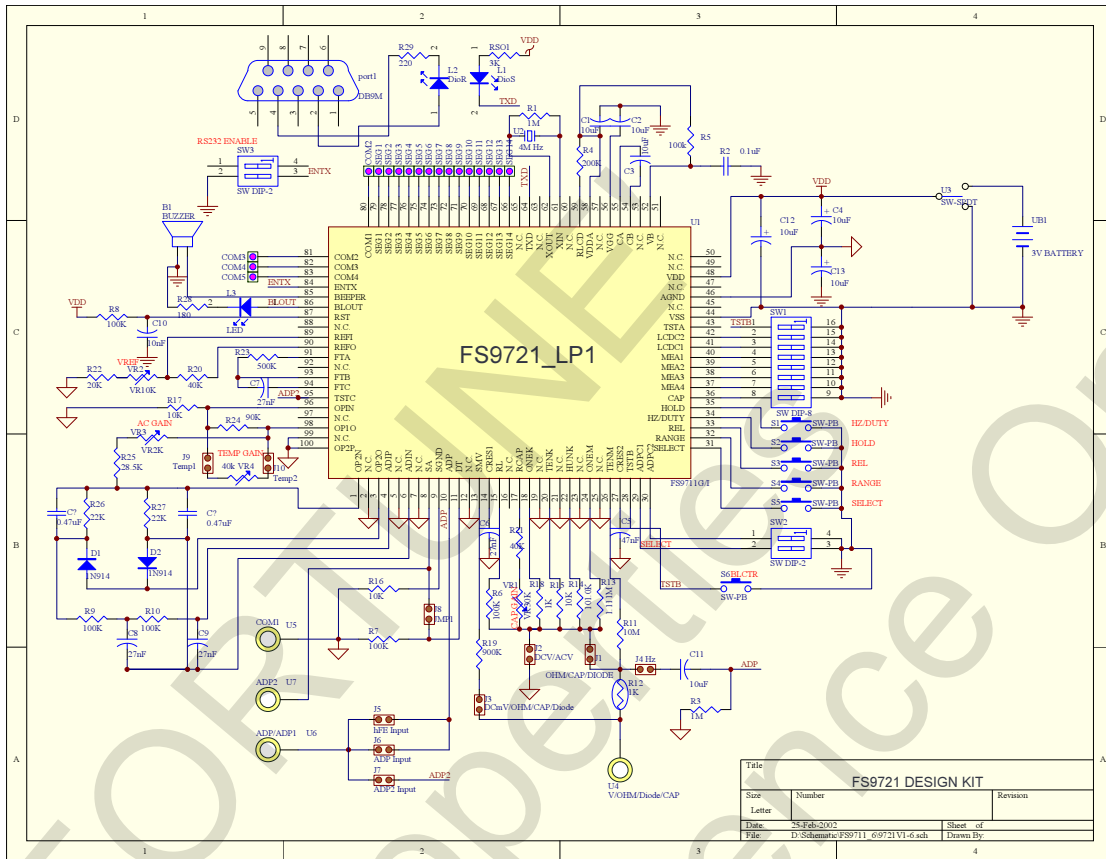

Diagram 38 Demo Board Schematic

FS9711_LPX Demo Board loactin:

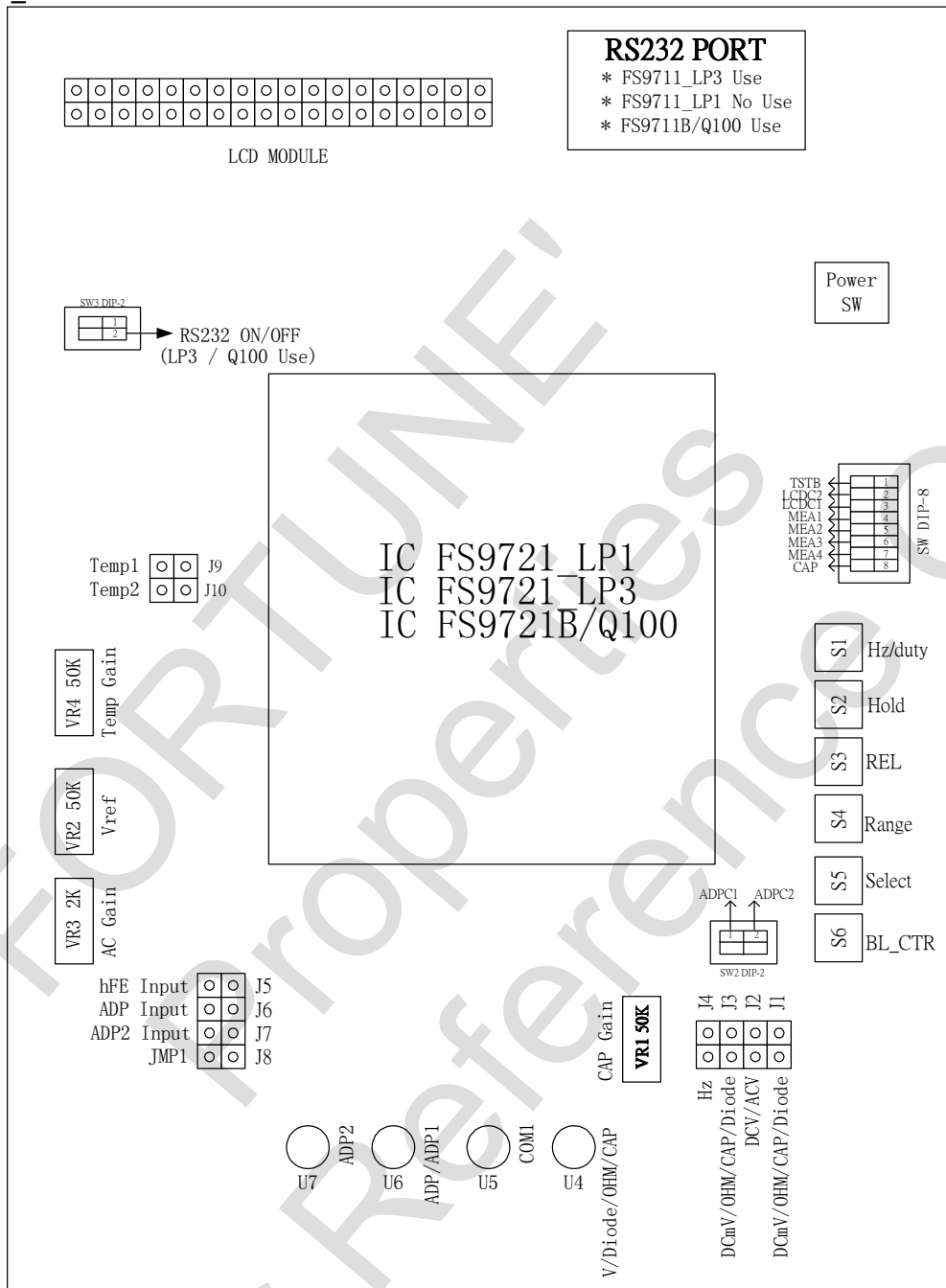

Diagram 39 Schematic

1. U4: Input Voltage, Resistance, Diode and Capacitance.
2. U5: Analog Signal to Ground.
3. U6: Input Voltage (mV), Hz and Duty Cycle.
4. U7: Unused. (Note: Use only in FS9721_LP3 & FS9721B/Q100.)
5. J1~J10: Please refer to "FS9721_LP1 Measurement Mode and Jumper Setup".
6. S1~S6: Please refer to "FS9721_LP1 Demo Board Schematic".
7. SW-DIP8: Please refer to "FS9721_LP1 Measurement Mode" (If switch SW to ON, it is Low Level)

8. FS9721_LP1 Measurement Mode:

MEA4	MEA3	MEA2	MEA1	Function Mode	ADPC2=0	ADPC2=1	Select(1->0->1)	Hz / duty
0	0	0	1	DCV				Hz / duty
0	0	1	0	ACV				Hz / duty
0	0	1	1	Ohm				
0	1	0	0	Hz/Duty				Hz / duty
0	1	0	1	CAP				
0	1	1	0	Beep / Diode	Beep / Diode	Diode / Beep	Beep / Diode	
0	1	1	1	uA	AC/DC	DC/AC	DC/AC	Hz / duty
1	0	0	0	V	AC/DC	DC/AC	DC/AC	Hz / duty
1	0	0	1	Ohm/Diode/ Beep/CAP	Diode/Beep/ CAP/Ohm	Ohm/Diode/ Beep/CAP	Ohm/Diode/ Beep/CAP	Hz / duty
1	0	1	0	A	AC/DC	DC/AC	DC/AC	Hz/duty
1	0	1	1	mA	AC/DC	DC/AC	DC/AC	Hz/duty
1	1	0	0	Diode				
1	1	0	1	Beep				
1	1	1	0	hFE				
1	1	1	1	Temp 2				

1. hFE is input 400.0mV from ADP(pin7) and AGND.
2. Temp. is input 40μV/°C from TSTC(pin75) and AGND.
3. ADPC1=1, the max. input of the current mode is 40mV~400mV.
4. ADPC1=0, the max. input of the current mode is 400mV~4V.

9. FS9721_LP1 Measurement Mode and Jumper Setup:

MEA4	MEA3	MEA2	MEA1	Function Mode	Jump	Input
0	0	0	1	DCV	J2	V/Diode/Ohm/CAP,COM
0	0	1	0	ACV	J2	V/Diode/Ohm/CAP,COM
0	0	1	1	Ohm	J1,J3	V/Diode/Ohm/CAP,COM
0	1	0	0	Hz/Duty	J4	ADP / ADP1,COM
0	1	0	1	CAP	J1,J3	V/Diode/Ohm/CAP,COM
0	1	1	0	Beep / Diode	J1,J3	V/Diode/Ohm/CAP,COM
0	1	1	1	uA	J3,J8	V/Diode/Ohm/CAP,COM
1	0	0	0	V	J2	V/Diode/Ohm/CAP,COM
1	0	0	1	Ohm/Diode/Beep/CAP	J1,J3	V/Diode/Ohm/CAP,COM
1	0	1	0	A	J3,J8	V/Diode/Ohm/CAP,COM
1	0	1	1	mA	J3,J8	V/Diode/Ohm/CAP,COM
1	1	0	0	Diode	J1,J3	V/Diode/Ohm/CAP,COM
1	1	0	1	Beep	J1,J3	V/Diode/Ohm/CAP,COM
1	1	1	0	hFE	J5	ADP / ADP1,COM
1	1	1	1	Temp	J7,J9,J10	ADP / ADP1,COM

17. Ordering Information

Product Number	Description	Package Type
FS9721_LP1		Die form (78 pins)
FS9721_LP1		100-pin QFP (Not Pb free package)
FS9721_LP1-PCE	Pb free package part number.	100-pin QFP (Pb free package)

18. Revision History

Ver.	Date	Page	Description
1.5	2004/04/09	31	<ol style="list-style-type: none"> 1. Change file name format from "FS9721_LP1 Data Sheet_V1.4.doc" to "FS9721_LP1_DataSheet_V15.doc". 2. Change page top and bottom space format. 3. Add CR-004 on the bottom page space. 4. Add ordering information.
1.6	2004/11/18	8	1. Revise the Diagram 3 78PIN Dice.
		31	Add revision history on the last page of the data sheet.
1.7	2005/07/8	8	<ul style="list-style-type: none"> ● Diagram 3 78PIN Dice in Ver. 1.6 is not correct. Revise it to the right one.
		31	Revise ordering information. Add Pb-free package part number.
1.8	2005/08/17	6,14	1. Add description of ADPC1 and ADPC2.
		10	1. In the "9.Technical specification", correct Capacitance measurement mode 4000 counts for 5120counts.
		19	1. Delete diagram 11 "4.5V power supply" and diagram 12 "6.0V power supply", and modify serial number after them.
		25	1. Add "Current Measurement (B) mode".
		28	1. Add description of " Temperature Measurement".
		32~33	1. In the 8 and 9, correct MEAS=1010 Ohm/Diode/Beep/CAP for MEAS=1001 Ohm/Diode/Beep/CAP.
1.9	2006/03/23	15	Modify the lcd display table according to new lcd display table.
		16-17	The Diagram 6 and Diagram 7,change the resistance R3 from 174K to 82K, the resistance R11 from 500K to 100K and the resistance R18 from 10K to 1K.
		19	The Diagram 8 Power Circuit, change the resistance R3 from 174K to 82K.
		23	Modify the Diagram 22 (Peak Commutation Circuit) as full wave rectification.
2.0	2014/05/22	2	Revised company address